

SU90 – ALUMINUM WALL SHELF

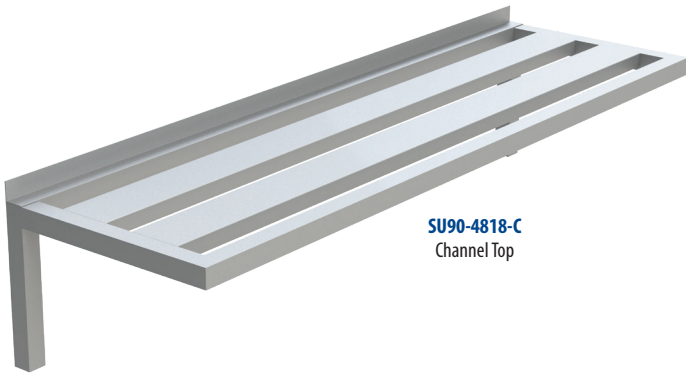

SU90-4818-C
Channel Top

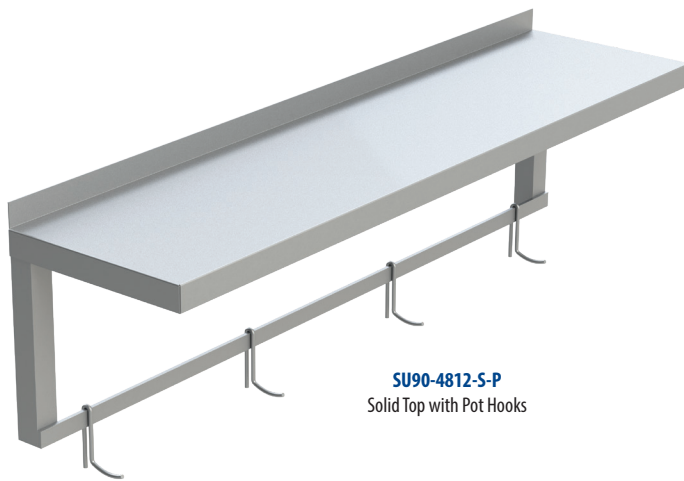

SU90-4812-S-P
Solid Top with Pot Hooks

Construction

- All Heavy-Duty extruded 6063 Aluminum Alloy
- Available in Standard 36", 42", 48", 54" and 60" Lengths
- Available in 12", 16" or 18" Depths
- Available with Channel, T-Bar or Solid Top
- Optional Pot Hooks
- Custom Sizes Available

Frame

- All welded 1 ½" square tubular frame
- Solid top is .090" thick
- Channel Shelf feature 4" E-Channel
- Mounting holes by others (on-site)

Mounting hardware not included.

EXAMPLE: SU90-4818-S-P (Aluminum Wall Shelf, 48 in. Width, 18 in. Depth, Solid Shelf, with Pot Hooks)

EX. break-down: SU90		-	48		20	-	S	-	P
Aluminum Wall Shelf		Width		Depth		Shelf Type		Wall Shelf Options	
SU90	Aluminum Aluminum Wall Shelf <i>All Aluminum Wall Shelves are 72" in Height</i>	Std. Widths (in.):		Std. Depths (in.):		C	4" E-Channel	P	Pot Hooks (1 hook per foot of shelf)
		36		12		TB	2.5" T-Bar		
		42		16		S	Solid		
		48		18					
		54							
		60							

Build Your Aluminum Aluminum Wall Shelf Part Number

Select a code (in **BLUE**) from each category and fill in the boxes below. Use this Part Number when you order your Aluminum Aluminum Wall Shelf

SU90	-				-		-	
SU90	-				-		-	

Choice Equipment Company, Inc. warrants to the original purchaser that all of its goods and services sold shall be free of defect in material or workmanship during the twenty-four (24) months, twelve (12) months on wheels and casters, from the date of shipment or performance, provided the product has been used within the following restrictions:

1. The product was used for its intended purpose.
2. The product was properly handled, stored, installed, maintained and operated.
3. The product was not loaded beyond the product's load capacity.
4. The product is cleaned and maintained with a cleansing agent generally accepted by the industry and the instructions of the specific agent are followed.
5. Any abuse or misuse of, changes to, alteration of, or improper maintenance of original equipment shall void this warranty in its entirety.

If any product provided by Choice Equipment Company, Inc. shows defect in material or workmanship, CEC will, at its option, repair or replace the defective product if (1) CEC has received notice of such defects within the specified warranty period, and (2) upon CEC's request, the defective items is returned at CEC's cost to a location designated by CEC.